



ACEROS ROSCADOS

VÁLVULA DE ESFERA 2 PC



1000 WOG (316)

(DISEÑO ESTÁNDAR): ASMEB16.34 GB/T12237

(EXTREMOS ROSCADOS): PT, BSP, BSPT, BSP, NPT, DIN2999, DIN259, DIN EN ISO228

(ESTILO DE PRODUCTO): Q11F-1000 WOG (P/R)

(PRESIÓN DE TRABAJO): PN16

(RANGO DE TEMPERATURA): 150 °C

(MATERIAL): ASTM-A351- CF8M

(PRUEBA E INSPECCIÓN): API598 JB/T9092

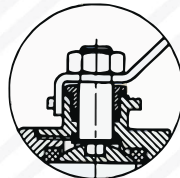
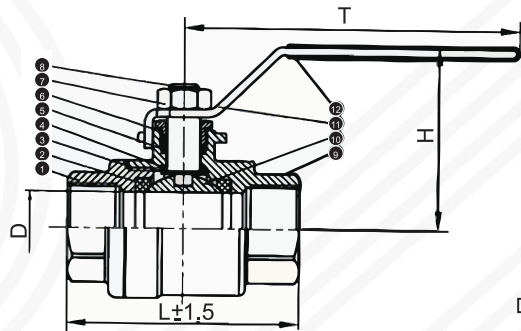

Sin dispositivo de bloqueo

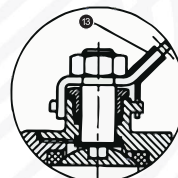

Con dispositivo de bloqueo



LISTA DE MATERIALES

No	Nombre de Parte	Material	Cantidad
1	CUERPO	CF8M	1
2	TAPA	CF8M	1
3	ASIENTO	PIFE+15% Grafito	2
4	JUNTA CONJUNTA	PIFE+15% Grafito	1
5	ARANDELA DE EMPUJE	PIFE+15% Grafito	1
6	EMPAQUE	PIFE+15% Grafito	1
7	GLÁNDULA	S201/S304	1
8	TUERCA	S201/S304	1
9	VÁSTAGO	S316	1
10	BOLA	S316	1
11	PALANCA	S201/S304	1
12	CUBIERTA DE PALANCA	PVC	1
13	CANDADO	S201/S304	1

CLASIFICACIÓN DE TEMPERATURA DE PRESIÓN

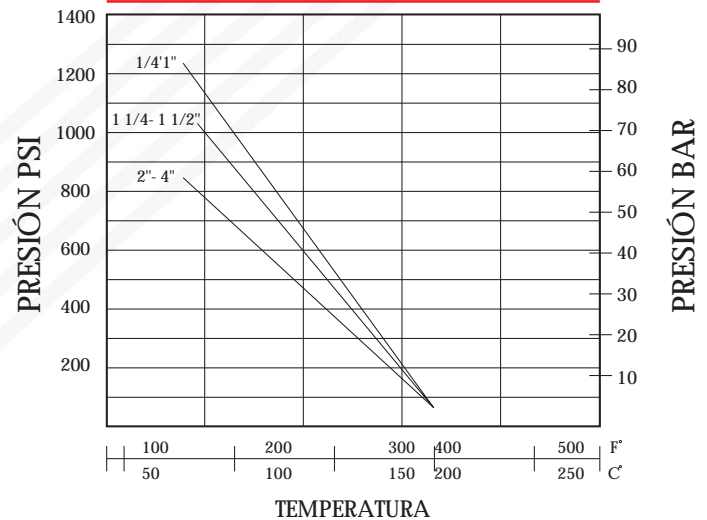

DIMENSIONES

TAMAÑO	1/4'	3/8'	1/2'	3/4'	1'	1 1/4'	1 1/2'	2'	2 1/2'	3'	4'
DN	8	10	15	20	25	32	40	50	65	80	100
D	10.5	10.5	15	20	25	32	38	50	65	80	100
L+ - 1.5	52	52	55	64	71	82	93	109	144	168	205
H	42	42	49	58	67	72	86	92	127	149	162
T	89	89	107	120	126	143	160	171	205	235	296
KG	0.195	0.19	0.235	0.37	0.56	0.85	1.14	1.595	3.59	5.225	8.745



ACEROS ROSCADOS

ACS CE NSF ISO9001:2008

VENTAS

Monterrey, NL (matriz)

Tels: (81) 8239-0074, 8239-0075

8212-0225, 8212-0226

México (Sucursal)

Tel: (55) 5715-0712 y 5714-2276

Guadalajara (Sucursal)

Tel: (33) 3619-2880 y 3650-3319

www.acerosroscados.com.mx