



ACEROS ROSCADOS

# VÁLVULA DE ESFERA 3 PC



## 1000 WOG (316)

(DISEÑO ESTÁNDAR): ASMEB16.34 GB/T12237

(EXTREMOS ROSCADOS): PT, BSP, BSPT, BSP, NPT, DIN2999, DIN259, DIN EN ISO228

(ESTILO DE PRODUCTO): Q11F-1000 WOG (C/P/R)

(PRESIÓN DE TRABAJO): PN16

(RANGO DE TEMPERATURA): 150 °C

(MATERIAL): ASTM-A351- CF8M

(PRUEBA E INSPECCIÓN): API598 JB/T9092

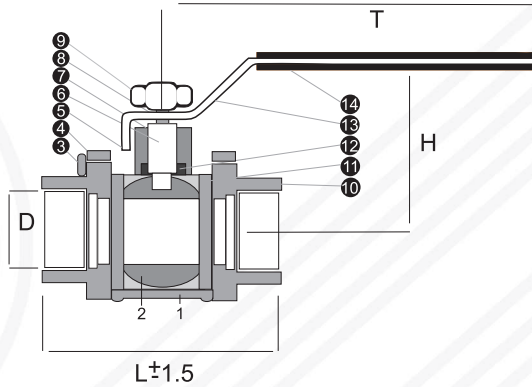

### LISTA DE MATERIALES

| No | Nombre de Parte     | Material         | Cantidad |
|----|---------------------|------------------|----------|
| 1  | CUERPO              | CF8M             | 1        |
| 2  | BOLA                | S316             | 1        |
| 3  | TORNILLO            | S201/S304        | 4 ~6     |
| 4  | TUERCA              | S201/S304        | 4 ~12    |
| 5  | ASIENTO             | PTFE+15% Grafito | 1        |
| 6  | VÁSTAGO             | S316             | 1        |
| 7  | ESTUPERO            | S201/S304        | 1        |
| 8  | EMPAQUE             | S201/S304        | 1        |
| 9  | TUERCA              | S201/S304        | 1        |
| 10 | TAPA                | CF8M             | 2        |
| 11 | ASIENTO             | PTFE+15% Grafito | 2        |
| 12 | ARANDELA DE EMPUJE  | PTFE+15% Grafito | 1        |
| 13 | PALANCA             | S201/S304        | 1        |
| 14 | CUBIERTA DE PALANCA | PVC              | 1        |
| 15 | CANDADO             | S201/S304        | 1        |

### CLASIFICACIÓN DE TEMPERATURA DE PRESIÓN

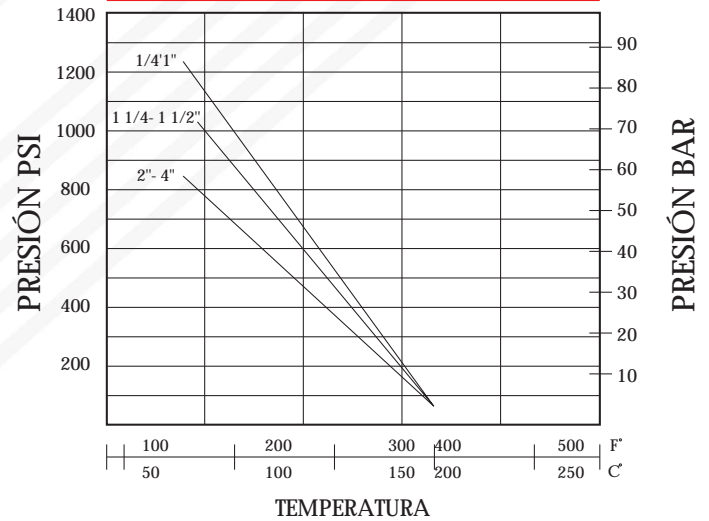

### DIMENSIONES

| TAMAÑO   | 1/4' | 3/8'  | 1/2' | 3/4'  | 1'    | 1 1/4' | 1 1/2' | 2'   | 2 1/2' | 3'   | 4'     |
|----------|------|-------|------|-------|-------|--------|--------|------|--------|------|--------|
| DN       | 8    | 10    | 15   | 20    | 25    | 32     | 40     | 50   | 65     | 80   | 100    |
| D        | 8    | 10    | 15   | 20    | 25    | 32     | 40     | 50   | 65     | 80   | 100    |
| L+ - 1.5 | 66   | 66    | 63   | 70    | 82    | 99     | 109    | 126  | 185    | 205  | 235    |
| H        | 51   | 51    | 56   | 64    | 69    | 80     | 89     | 101  | 121    | 141  | 169    |
| T        | 89   | 89    | 107  | 120   | 126   | 143    | 160    | 171  | 205    | 235  | 296    |
| KG       | 0.36 | 0.333 | 0.42 | 0.615 | 0.835 | 1.255  | 1.725  | 2.43 | 4.915  | 7.49 | 13.515 |



ACS CE ISO9001:2008

VENTAS

Monterrey, NL (matriz)

Tels: (81) 8239-0074, 8239-0075

8212-0225, 8212-0226

México (Sucursal)

Tel: (55) 5715-0712 y 5714-2276

Guadalajara (Sucursal)

Tel: (33) 3619-2880 y 3650-3319

[www.acerosroscados.com.mx](http://www.acerosroscados.com.mx)